



SCSA Competition Rules

July 2020



© Copyright 2020 by SCSA® Inc.
Burlington, WA 98233

APPENDIX E1 – Stage Diagrams

E1.1 – 5 to Go, SC-101

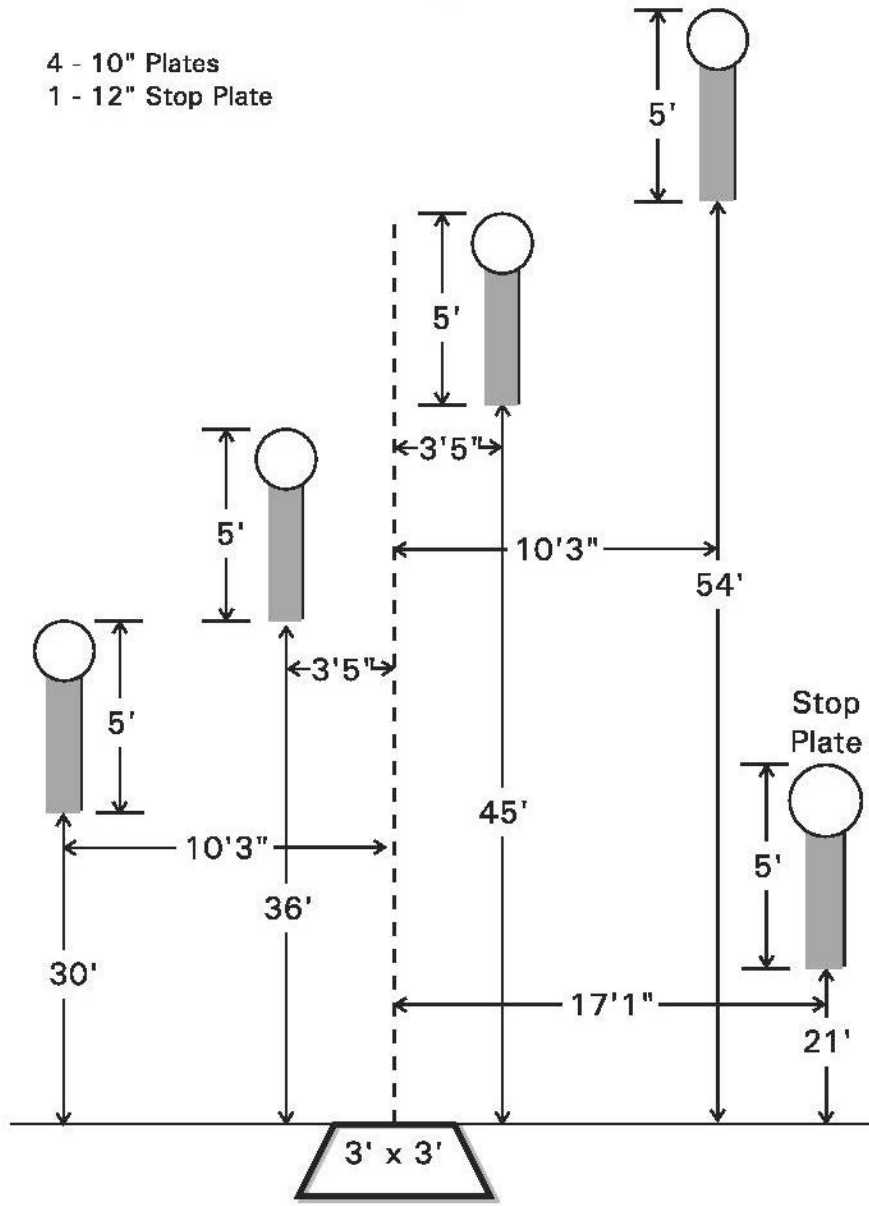

Five To Go

Best 4 of 5 runs

E1.2 – Showdown, SC-102

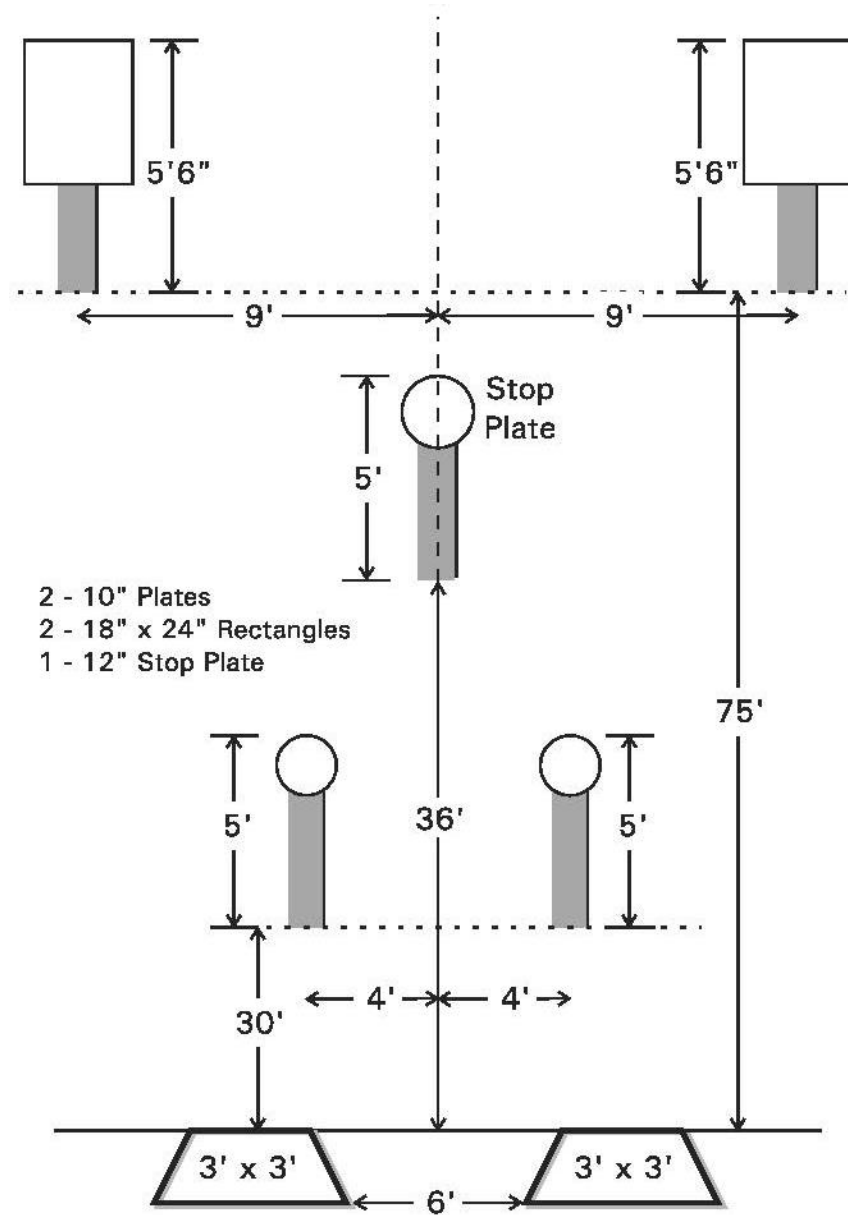

Showdown
Best 4 of 5 runs

E1.3 – Smoke & Hope, SC-103

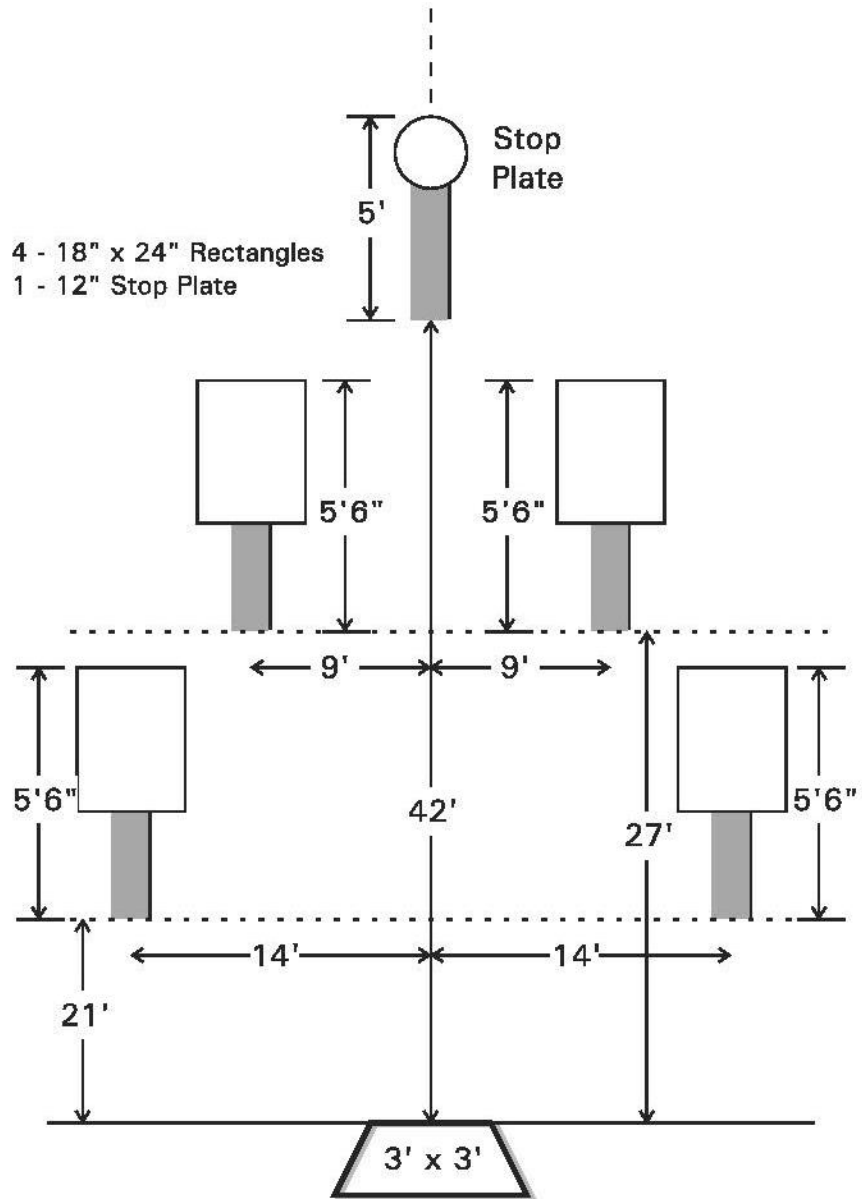

Smoke & Hope
Best 4 of 5 runs

E1.4 – Outer Limits, SC-104

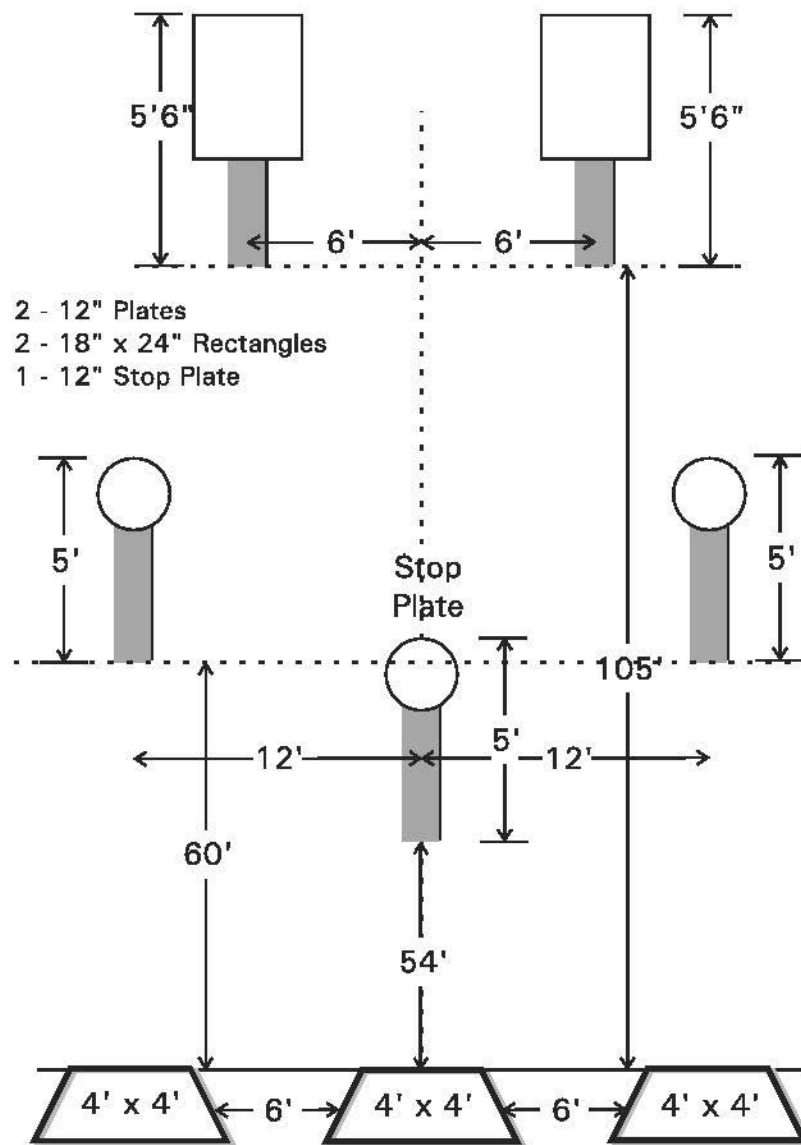

Outer Limits
Best 3 of 4 runs

E1.5 – Accelerator, SC-105

- 1 - 10" Plate
- 1 - 12" Plate
- 2 - 18" x 24" Rectangles
- 1 - 12" Stop Plate

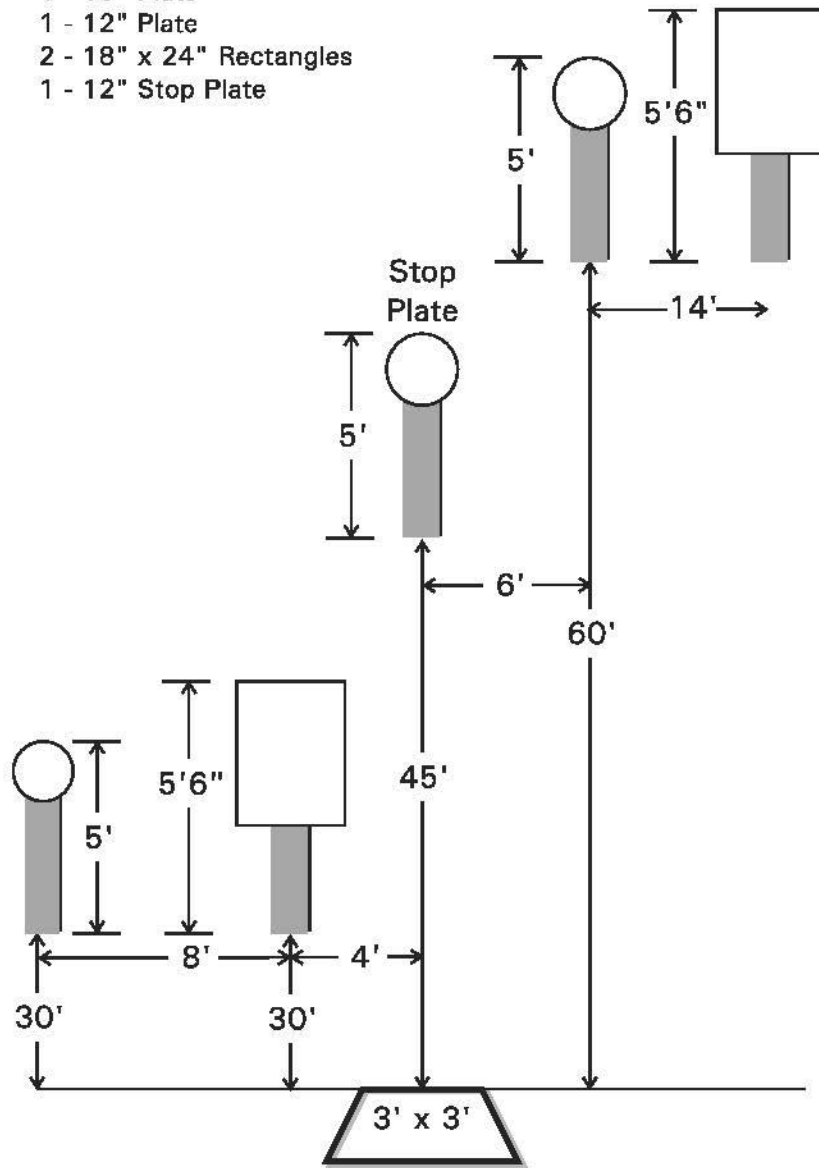

Accelerator
Best 4 of 5 runs

E1.6 – The Pendulum, SC-106

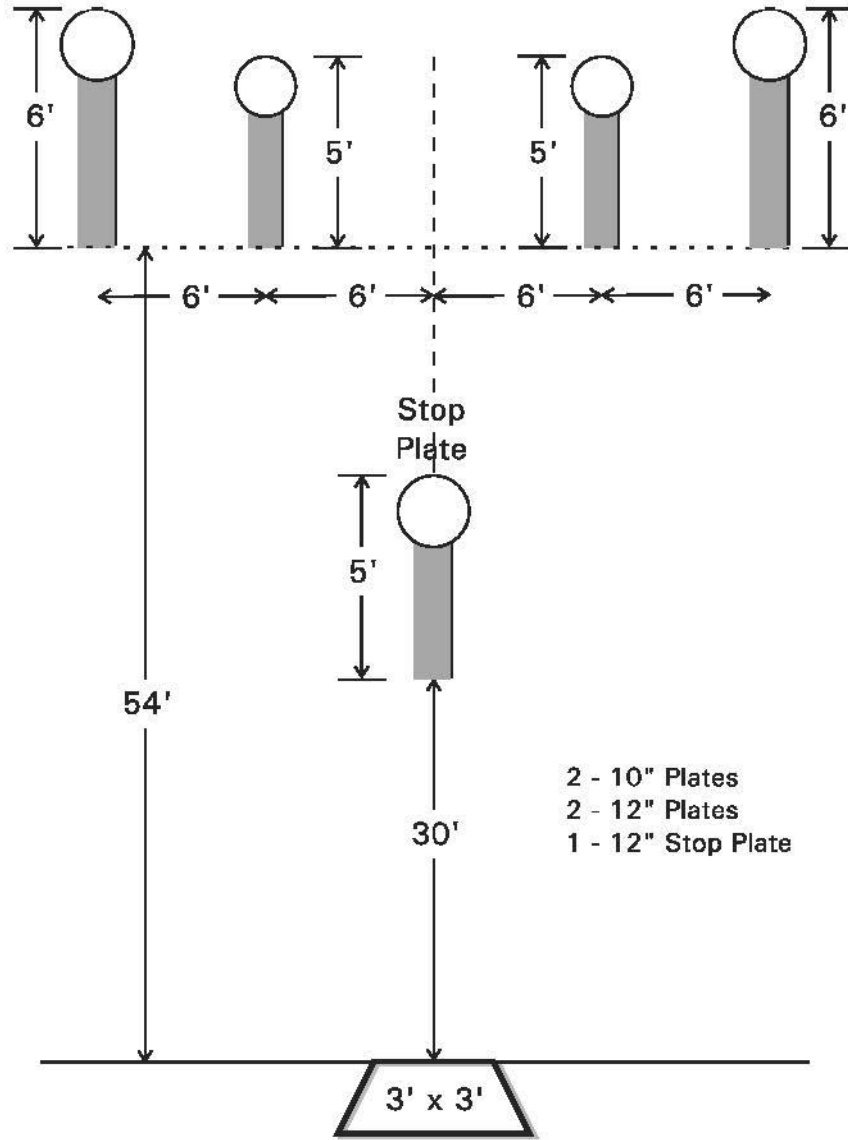

Pendulum
Best 4 of 5 runs

E1.7 – Speed Option, SC-107

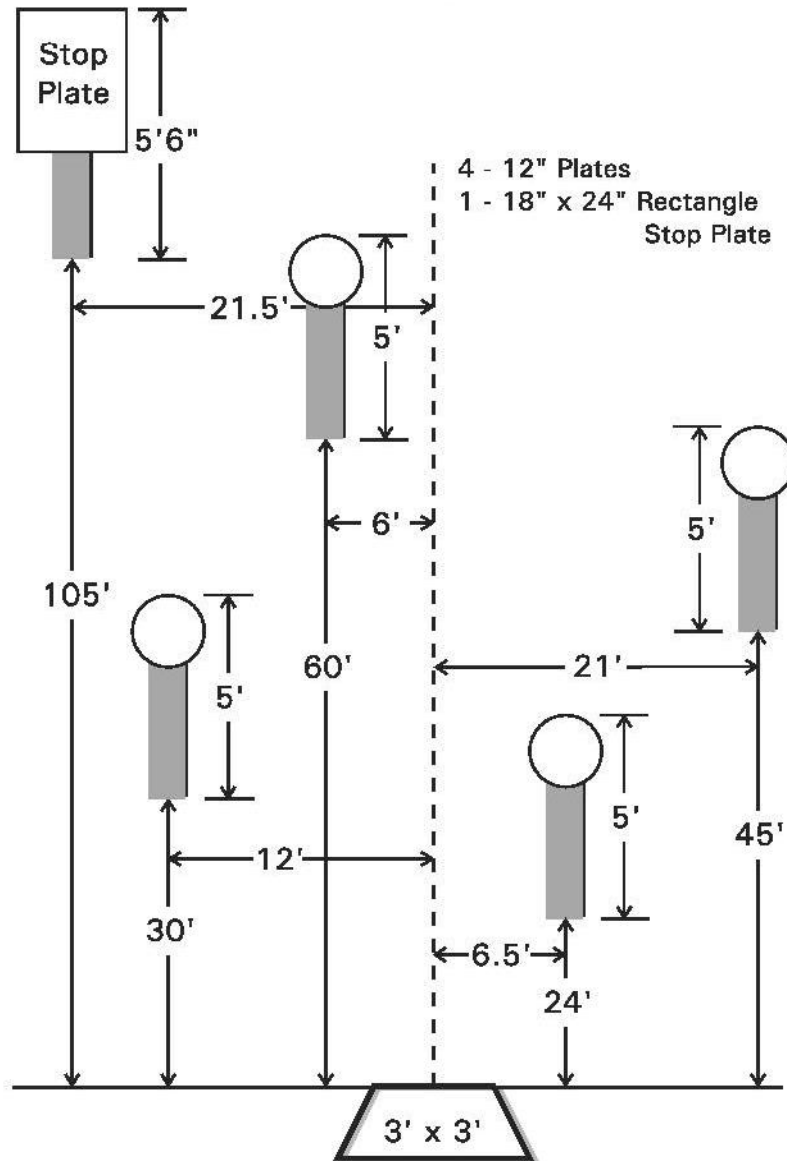

Speed Option
Best 4 of 5 runs

E1.8 – Roundabout, SC-108

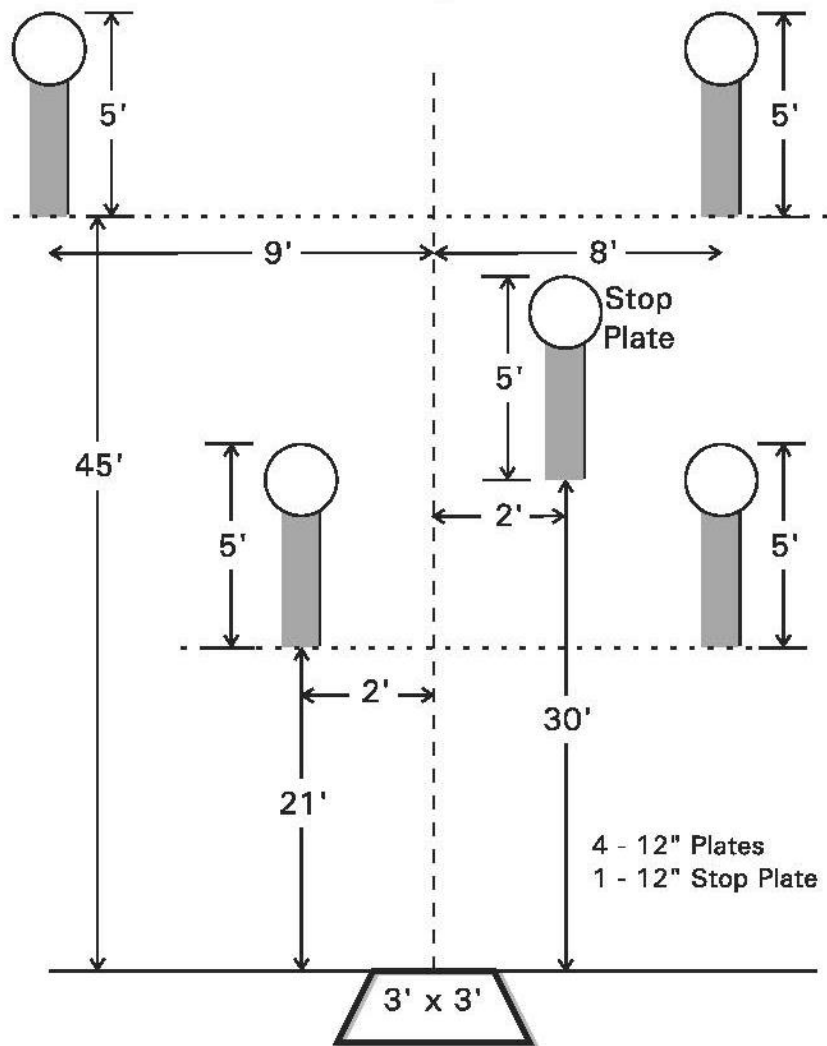

Roundabout

Best 4 of 5 runs